

TOM 5 STREETER



 **boavista**
solutions
...THE WAY

TOM 5 STREETER



Nova Geração

O novo chassi de alumínio da cadeira de transporte Tom 5 é fabricado com o método de produção ALUX de alta tecnologia, que aproveita as vantagens da liga de alumínio e titânio, proporcionando uma combinação única de leveza e robustez.

O assento é reversível, basculante e reclinável. Permite ainda ajustes em todas as posições graças ao seu sistema Monoslíde.

Grças a uma vasta gama de acessórios é possível adaptar-se a vários tipos de utilizadores. Com grande mobilidade estas cadeiras são as mais leves da sua gama. Vêm equipado com rodas maciças traseiras de 260 mm. A Tom 5 Streeter é uma cadeira tanto de interior como de exterior.

Equipamento Standard

- Cadeira encartável
- Assento extraível, reversível
- Assento basculante regulável em largura e profundidade
- Costas com suporte laterais totalmente reclináveis
- Costas ajustáveis em altura
- Apoios de pés reguláveis em ângulo e altura
- Todas as rodas são maciças
- Arco da Frente extraível
- Barra de empurrar regulável em altura
- Cesta inferior e protector de barras laterais
- Chassi de alumínio Alux
- Cumpre os requisitos da norma EN7176/19 capacitando-a para o transporte em veículos
- Cinto de 2 pontos Bodypoint Tam. XS ou S



- Rodas maciças de baixo perfil



- Suspensão Frontal



- Encartável



- Chassi para interiores, fácil de manobrar em espaços pequenos



TOM 5 STREETER

Sistema Monoslido

A regulação do assento (profundidade) e largura e das costas (altura) é efectuada com muita precisão graças a nova estrutura de assento Monoslido da Patron Bohemia, que é formada por um carril central deslizante. A base dos apoios de pés são ajustáveis em ângulo e altura, assim como todo o conjunto é regulável em inclinação. É reclinável e basculante.

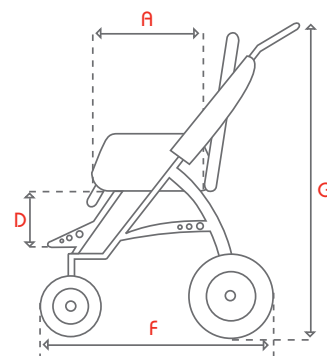
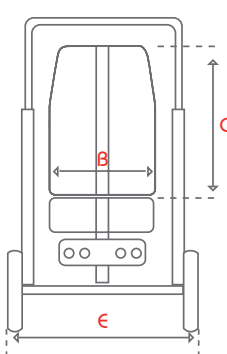

R41



R40



R39



R37**



R36**

Tamanho	MINI	STANDARD	MAXI
A- Profundidade do assento	20-27	23-31	29-40
B- Largura do assento	21-28	24-34	28-38
C- Altura das costas	45-58	52-69	55-70
D- Altura dos patins	5-27	15-36	18-40
E- Largura Total	59.5	63.5	67
F- Comprimento total	81	83	84
G- Altura frontal (com barra frontal)	85-110	90-115	90-117
Regulação ângulo assento	+38°/-28°	+38° / -28°	+38° / -28°
Regulação do ângulo costas	0° / 175	0° / 175°	0° / 175°
Carga Máxima	35 kg.	40 kg.	50 kg.
Peso	15.5 kg.	17 kg.	18.3 kg.
Travão	de pé	de pé	de pé
Comprimento total da cadeira encartada	92	94	94
Largura total da cadeira encartada	59.5	63.5	67
Altura total da cadeira encartada	35	36	40

* As cores R41, R 40 e R39 estão disponíveis em stock

** A cor R37 e R36 só estão disponíveis mediante encomenda e não serão aceites devoluções deste produtos.



TOM 5 STREETER

ACESSÓRIOS

Suporte de cabeça
(par)



Suporte Laterais Tronco
(par)



Separador de pernas



Taco Abdutor



Calção Abdutor



Cinto Pélvico Comfort



Cinto de 2 pontos
Comfort



Cinto de 4 pontos
Comfort



Cinto de 5 pontos



Colete de fixação com
fecho



Arnes

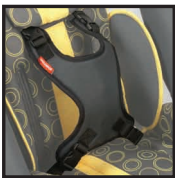

Suporte de pernas com
fixação



Fita para pés



Tabuleiro



Chassi Interior



Capota com capa
Impermeável



Capota de sol



Posicionador ajustável
para capota



Fixação reclinável para
Espásticos



Saco de Inverno



Bolsa Activ



Extensão protector
lateral



Cesta HD (alta densidade)



Cesto Metálico

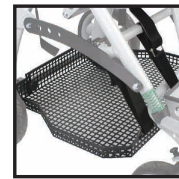

Protector do suporte de
barra frontal



Apoio de cabeça em "U"



Suporte de Nuca



Cinto Abdominal



Suporte Lombar



em parceria com:

 rehagirona

BOAVISTA SOLUTIONS, LDA
Rua Engº Ezequiel de Campos, 541-2º . Zona Industrial do Porto
4100-233 Porto Portugal
Tel. +351 22 615 11 50 . Fax. +351 22 615 11 52
info@boavistasolutions.eu www.boavistasolutions.eu

 patron